

**RCMB KIRK FIELD
SOUND TEST**

PER THE CONFIRMATION BY A MAJORITY VOTE, AT THE SCHEDULED MEETING OF MAY 9TH, 2006, SOUND TESTING OF ALL AIRCRAFT AT KIRK FIELD WILL BE PERFORMED BY THE APPOINTED FIELD MARSHALL IN ACCORDANCE WITH THE FOLLOWING CRITERIA:

- 1. THE dB SOUND METER SHALL BE POSITIONED 9 FEET FROM THE RIGHT HAND SIDE OF THE PLANE ON A LINE PERPENDICULAR TO THE LONGITUDINAL CENTER LINE OF THE FUSELAGE.**
- 2. THE dB SOUND METER TO BE POSITIONED 30 INCHES ABOVE THE GROUND LEVEL ON WHICH THE PLANE IS SITTING.**
- 3. THE SURFACE ON WHICH THE PLANE SHALL BE PLACED WILL BE GRASS.**
- 4. THE SOUND LEVEL WILL BE DETERMINED WITH THE ENGINE OPERATING AT FULL THROTTLE, AND SHALL NOT QUALIFY IF THE SOUND LEVEL IS DETERMINED TO EXCEED 95 dB.**

5/19/06

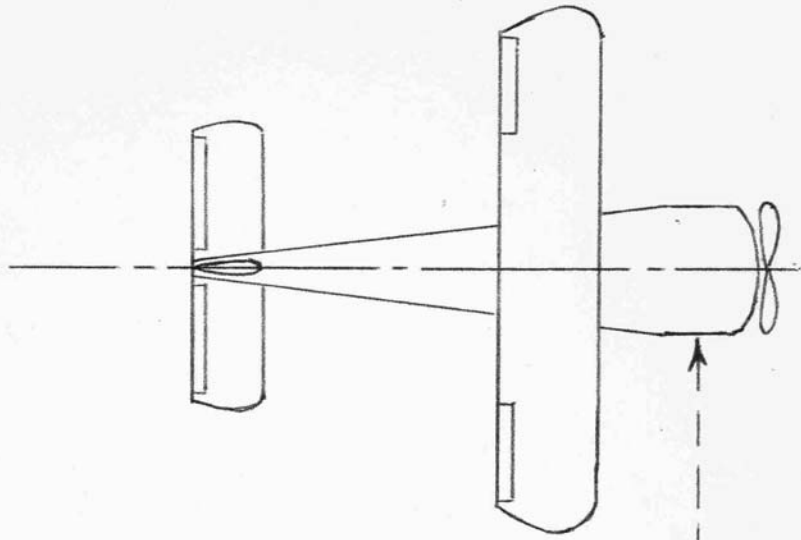

9 FT

Maximum 95 Db @
Full Throttle Setting
Soft (Glass) Surface

"A" Scale
"Slow" Response



